

# THE GREEN QUARTER

WEST LONDON

## THE HARRIS



**Berkeley**  
Designed for life



THE HARRIS

## CONTENTS

**03**

The Green  
Quarter

**04**

Parkside

**06**

Parkside Yards  
& Tree Nursery

**10**

Masterplan

**12**

The Harris

**16**

The Parkside Club

**22**

Interior  
Inspiration

**24**

Interiors

**32**

Palette Styles

**36**

Specifications

**38**

The Harris  
Floorplans

**54**

Why Berkeley

**58**

MyHome Plus

**62**

Contact

# REMARKABLE BY NATURE

## WELCOME TO THE GREEN QUARTER

The Green Quarter is no ordinary place to live. Here, you'll enjoy the benefits of modern urban living in a truly remarkable setting, with nature at its very heart.

The Harris is one of the latest addition to the transformation of this former brownfield site into one of the most biodiverse neighbourhoods in the UK.

Crafted by renowned interior design studio Atellior, The Harris' one and two-bedroom apartments feature timeless material palettes designed for style with sustainability in mind. Apartment balconies overlook residents' podium gardens and out across Central Gardens, the 4.5-acre landscaped park that is the focal point of The Green Quarter.

Offering the convenience of a wide range of residents' facilities, you'll also enjoy the flexibility of super-fast connections across London with the Southall station only a short stroll away.

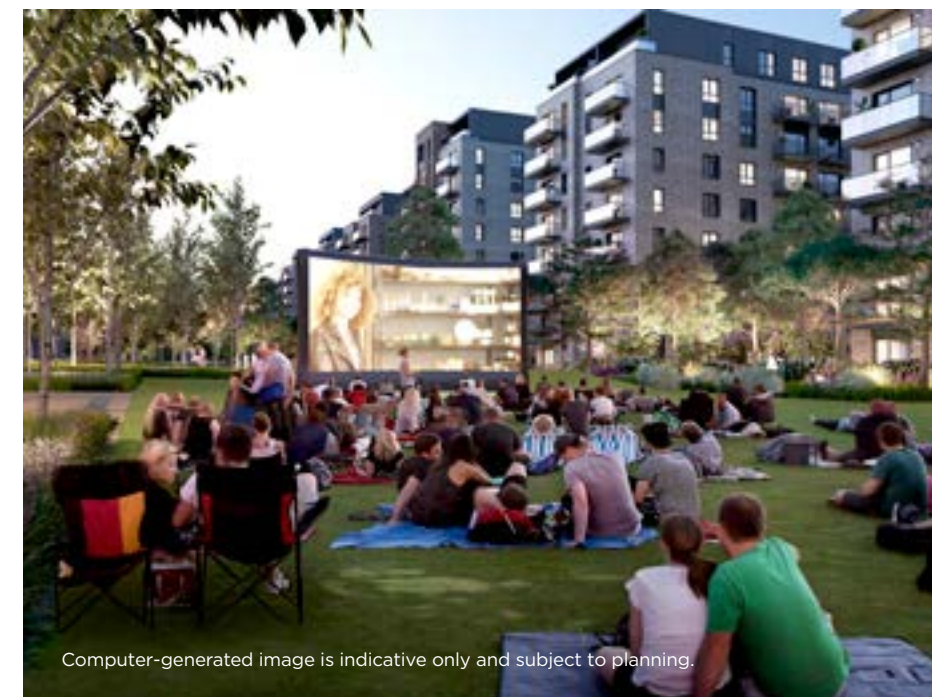

Computer-generated image is indicative only and subject to planning.

# PARKSIDE

**Between the apartments and the tree-lined boulevard is a series of neighbourhood spaces the community can use.**

Spanning almost the entire length of the 4.5-acre Central Gardens, Parkside is the pioneering neighbourhood at The Green Quarter.

Apartments set along the tree-lined boulevard offer striking views across these expansive gardens, including trickling waterways, a community amphitheatre and play spaces.

# PARKSIDE YARDS & TREE NURSERY



Parkside Yards at The Green Quarter has added a new cultural space and exciting arts programme to the community and features a ceramics studio, farm shop, community centre, café, clothes store and an airstream offering pizzas. This will also add to the expanding parkland in the area with a pioneering tree nursery, woodland trail and children's play area with a jumping pillow.



Parkside Yards is a vibrant new hub, bringing communities together through an exciting arts programme, flexible working spaces, and an outdoor piazza at its heart offering opportunities to eat, meet, drink, shop and play against the backdrop of green surroundings.



THE TREE NURSERY

Designed in line with The Green Quarter's aim to be one of the country's most biodiverse new places, a new on-site tree nursery has been created at Parkside Yards, one of the first at a UK development. The nursery currently features over 600 air-potted trees, all from species native to the British isles including Hornbeam, Black Alder, London Plane, Crab Apple, Wild Cherry, Lime and Silver Birch.

**600**  
AIR-POTTED TREES  
ALL FROM SPECIES NATIVE  
TO THE BRITISH ISLES



**House of A.E.I.O.U.** 1  
Discover a contemporary lifestyle store offering a wide range of goods from art supplies, books, homeware, greeting cards, gifts and stationery to hardware and functional products to support your daily lifestyle.  
**Wednesday to Saturday 10am - 5pm**  
**Sunday 11am - 2pm**



**Pinsafresco Pizza** 2  
Discover Pinsafresco. The home of authentic Pinsa Romana pizza, straight from the heart of Italy.  
**Thursday to Saturday 12pm - 10pm**  
**Sunday 11am - 4pm**



**Tree Nursery, Nature Trail and Children's Play Areas** 3  
Step into a haven where trees are nurtured with purpose. The on-site tree nursery at Parkside Yards is an integral part of our commitment to a greener future.  
**7 days a week 8am - 8pm**



**Farm Café** 4  
Introducing Farm Café, a haven for food enthusiasts and lovers of organic goodness.  
**Monday to Saturday 8am - 4.30pm**  
**Sunday 9am - 4.30pm**



**Farm Shop** 5  
Enjoy browsing Southall's newest organic grocery store in a relaxed, welcoming environment.  
**7 days a week 8am - 8pm**



**OPEN Southall** 6  
Building on the success of OPEN Ealing, OPEN Southall is poised to be a vibrant hub for the community, local artists, entrepreneurs, and art enthusiasts alike.  
**Programme of activity coming soon!**



A woodland nature trail for children runs through the green space, featuring carved wooden animal statues. Once matured, they will be planted around the development, creating habitats for wildlife, improving air quality and helping us foster a greener and more sustainable future for generations to come.

# THE HARRIS

The homes at The Harris are located within the second stage of Parkside, one of four character areas at The Green Quarter.

As part of a thriving neighbourhood, you'll be able to enjoy events at the amphitheatre as well as play spaces and trails threaded through the leafy expanse of Central Gardens - an expansive new public park for the whole community. For a little extra rest and relaxation, the secluded residents-only podium garden at the foot of your apartment building is the perfect spot.

## THE HARRIS

### Apartment Type

1 Bedroom	36
2 Bedrooms	48

## The Green Quarter Masterplan

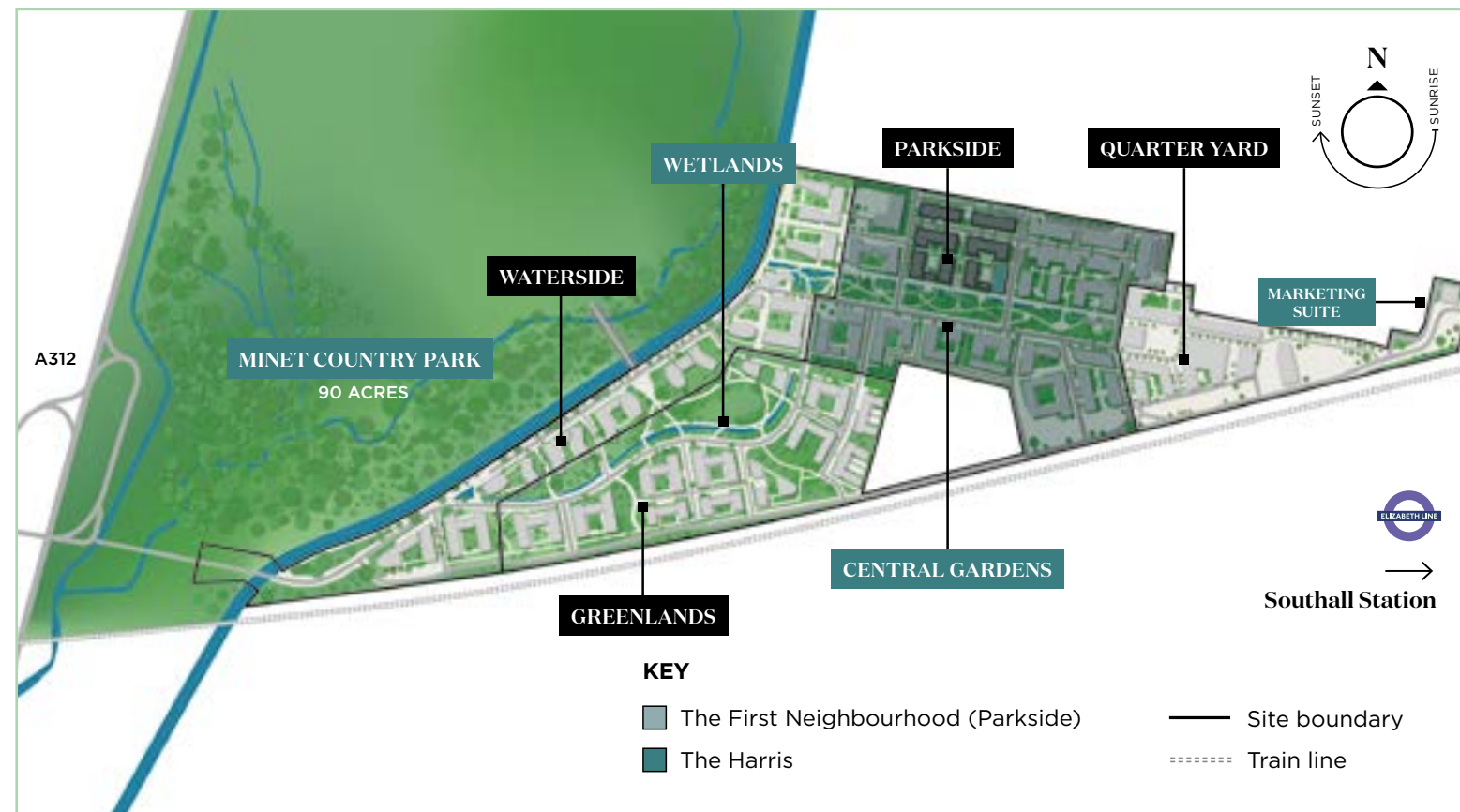

Maps are not to scale and show approximate locations only. The siteplan is indicative only and subject to change and subject to planning. In line with our policy of continuous improvement we reserve the right to alter the layout, building style, landscaping and specification at anytime without notice. \*Right to park only.

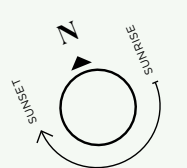

# THE HARRIS

The Harris is one of the latest apartment buildings at The Green Quarter to draw on the beauty and tranquillity of English botanical gardens. Named after the Harris Garden in Berkshire – home to thousands of plant species – The Harris is at one with nature.

For residents looking for a healthier lifestyle, the proximity to the canal provides the perfect starting point to enjoy a walk or run in the fresh air. Overlooking the green expanse of Central Gardens and private podium gardens, The Harris is built for sustainability and wellbeing. With green roofs and architectural flourishes that attract sunlight into bright, open interiors, the whole apartment building combines organic textures to great effect.

THE HARRIS





## A DIFFERENT PERSPECTIVE

Spacious private balconies offer wide-ranging views out across The Green Quarter. Below, the mature plants and trees of Central Gardens create a wide green avenue that leads from the Quarter Yard at one end of The Green Quarter all the way to the canal at the other.

“At The Green Quarter we believe that the benefits of nature and the sense of wellbeing that nature brings should be part of everyday life.”

— KYM JONES Applied Landscape Design



# THE PARKSIDE CLUB

From the moment you pick up your keys, you'll have access to all the exclusive amenities The Green Quarter already has to offer. Residents-only facilities are just a short walk across Central Gardens and include a relaxing lounge and co-working space as well as a fully-equipped gym, fitness studio and much more.

- FACILITIES INCLUDE:
- GYM
  - LOUNGE & CO-WORKING SPACE
  - CONCIERGE
  - COFFEE STATION
  - SCREENING ROOM
  - MEETING ROOM
  - PARKING†

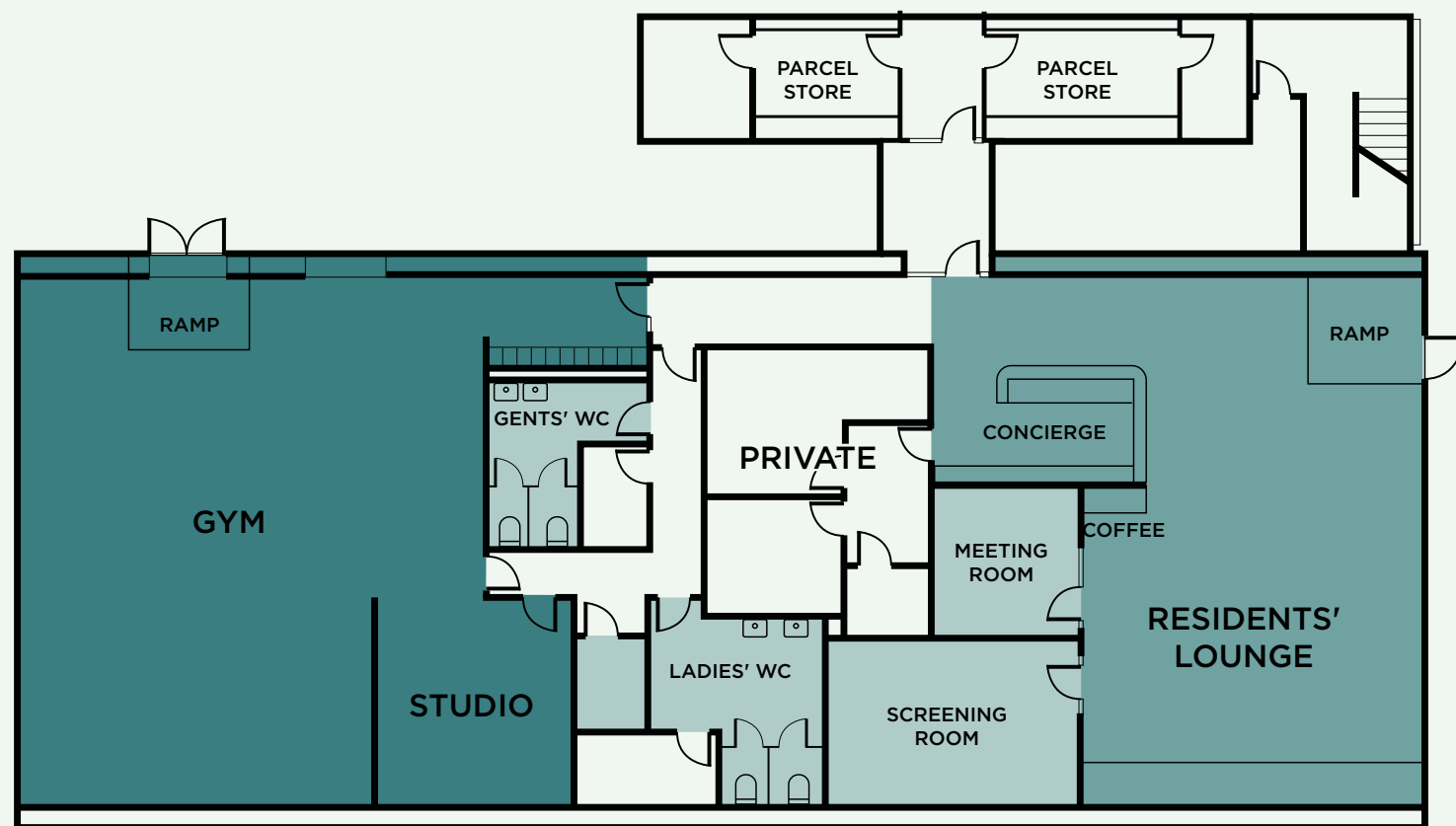

## THE PARKSIDE CLUB LAYOUT

- GYM AREA
- RESIDENTS' LOUNGE
- FACILITIES

The Parkside Club layout shown depicts the current residents' facilities. Further amenities/facilities including a swimming pool will be completed at a later date. Floorplan layout indicative only and is subject to change. †Subject to extra cost.

# RESIDENTS' LOUNGE



The Green Quarter concierge is on-hand to take care of you. If you're working from home, you can spend as much time as you like in a space designed to feel like an extension of your own home - the dedicated co-working space with super-fast broadband plus a coffee station for you to pick up your daily beverage.



# CONCIERGE

# GYM



# SCREENING ROOM

# CANAL-SIDE CAFÉ



As The Green Quarter community continues to grow, so will the residents-only facilities. You'll soon enjoy access to even bigger and better amenities as well as a new swimming pool.\*

## SWIMMING POOL



“Berkeley is well-known for quality, so we were excited to search out new ways to ensure everything flows seamlessly – from each apartment, through the building and out onto the gardens outside.”

— UNA BARAC ATELLIOR



## INSPIRED INTERIORS

Interior designer, Una Barac at the Atellior studio, tells us why they are so excited to work with Berkeley and what makes the interiors at The Harris quite unlike anything else.

### OUR VISION FOR THE INTERIORS AT THE HARRIS BEGAN WITH THE IDEA OF NATURE FOLLOWING YOU INDOORS.

We wanted to continue Berkeley's attention to detail and commitment to creating exceptional places that have something intrinsically special about them. So our concept was built on effortlessly connecting the outdoors to what's inside, and vice versa. This also gave us an opportunity to produce two very distinct colour palettes so we could offer residents two very different interior styles to choose between.

### ‘THE EVERGREEN’ IS A TIMELESS AND ELEGANT INTERIORS PALETTE, WHEREAS ‘THE INDIGO’ IS A FINGER-ON-THE-PULSE KIND OF STYLE.

As the name suggests, The Evergreen was inspired by nature and has softer details. The green tiling and timber units not only connect to nature, they also provide residents with a blank canvas on which to make their mark. The Indigo was informed by warehouse-style architecture and heritage brick buildings which brings home the history of the site. This brings with it darker tones and stronger colour contrasts that make it much less subtle and much more of a statement design.

### IT IS THE MATERIAL DETAILS THAT REALLY EMPHASISE THE QUALITY OF THESE BERKELEY HOMES.

There are so many examples but we love the wooden shelving. We pride ourselves on incorporating bespoke joinery into our designs and the open kitchen shelving just allows you to picture all your favourite things in one place.



### ‘REMARKABLE BY NATURE’ HAS BEEN THE DEFINING ELEMENT ACROSS ALL THESE DESIGNS.

One thing that is so remarkable about nature is its longevity, and this is reflected in the way we have chosen materials for sustainability as well as style. Berkeley also gave us a great opportunity to do something different with The Harris. We love the details in each apartment – like the pendant lights in the bathrooms – but also some of the bigger features of the building itself, including the stunning entrance lobby. Anyone who sees it for the first time really will feel as if nature has followed them inside before being greeted by the kind of space you might only ever find in a grand upscale hotel.



# MAKE YOUR MARK

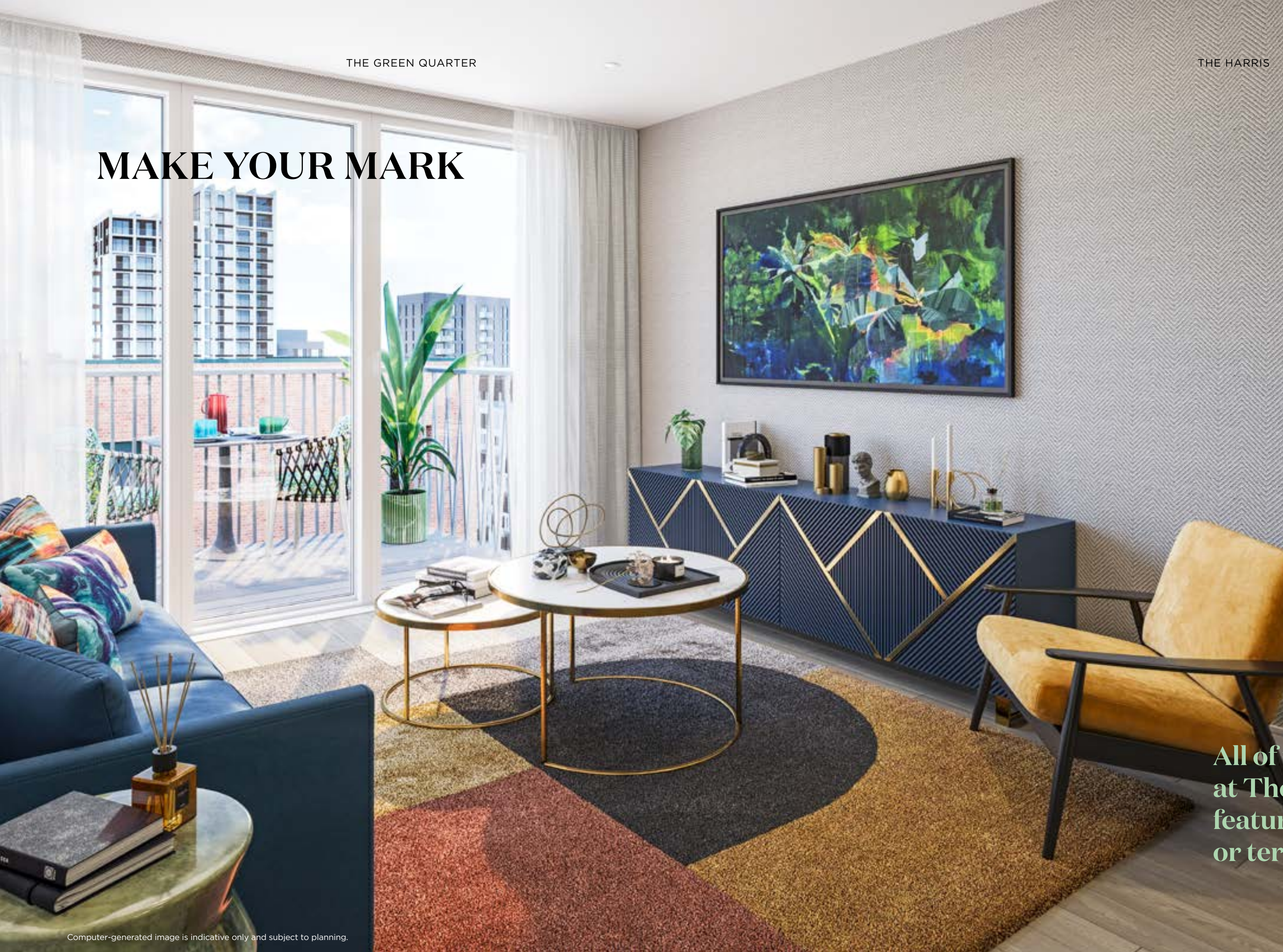

Drawing on its enviable position rising high beside Central Gardens, The Harris offers a choice of apartments that all feature private balconies. With two carefully considered material palettes providing the perfect backdrop for your own interior style, these are generous, bright and airy living areas filled with natural light. The perfect spaces for you to simply sit back and unwind.

All of the apartments at The Green Quarter feature private balconies or terraces.

Computer-generated image is indicative only and subject to planning.

## THE SPACE TO ENTERTAIN

The interior designers have created two distinctly different styles to suit a range of tastes. The Evergreen brings earthy tones and a seamless connection between the timber style flooring and custom-fitted cupboards with handleless soft-close doors. The Indigo offers a series of marked contrasts.

Each design concept includes integrated energy-efficient appliances as well as matte black brassware. And there is ample room to bring together friends and family – making these the kind of spaces designed to be shared.

**These are apartments designed for modern living. The kind of spaces in which you'll feel equally comfortable entertaining or kicking off your shoes and taking it easy.**

Stylish contemporary designs featuring natural timber flooring.



Computer-generated image is indicative only and subject to planning.

## A RELAXING RETREAT

At The Harris, you can turn your bedroom into the space you've always dreamed of. Outgoing and adventurous or pared back and natural, you get to style your private sanctuary. Deep, luxurious carpets feel soft beneath your feet, while the adjustable recessed lighting gives you the chance to dial things down and settle in for the evening.

These bedrooms come complete with floor-to-ceiling fully fitted wardrobes giving you ample storage space.\* With huge windows overlooking The Green Quarter and plenty of room to make it your own, these softly sophisticated bedrooms are the ideal place to get away from it all.







## MATERIAL DIFFERENCE



Bathrooms at The Harris add a touch of drama to what are all too often just functional spaces. Emphatic details like the matte black vanity mirror with internal shelving, the monoblock matte black mixer taps and the electric heated matte black towel rail give these bathrooms a certain edginess.

Low-hanging, smoked-glass pendant lamps make it feel like you're enjoying time in your very own boutique hotel. And the vertically aligned, bold and coloured tiles combined with lighter tiles in asymmetrical patterns make these the kind of spaces your visitors will tell their friends about.

# PALETTE STYLES

At The Harris, there are two colour palettes designed with materials handpicked for sustainability as well as style.

Be inspired by contemporary interior options and choose the home of your taste, finished in either The Indigo or The Evergreen.



Available to selected homes only. Showhome photography is indicative only and subject to change. Your attention is drawn to the fact that it may not be possible to provide the branded products as referred to in the specification. In such cases a similar alternative will be provided. Berkeley reserves the right to make these changes as required. A number of choices and options are available to personalise your home. Choices and options are subject to timeframes, availability and change.

Focusing on the signature look and feel of the building's architecture, The Indigo is a bold, contemporary design.



**KITCHEN**  
Graphite grey cupboards with dusk tiles.

# THE INDIGO PALETTE



**BATHROOM**  
Stylish bathrooms with feature vanity tiles.



Whisper tiles

**KITCHEN**

Green smoke cupboards with whisper coloured tiles.

Referencing the natural world outside, The Evergreen offers an organic backdrop onto which you can add your own style.

# THE EVERGREEN PALETTE

The Evergreen features subtle green and earthy tones, referencing the natural world just outside, and a seamless connection between the timber style flooring and customised cupboards with handleless soft-close doors.

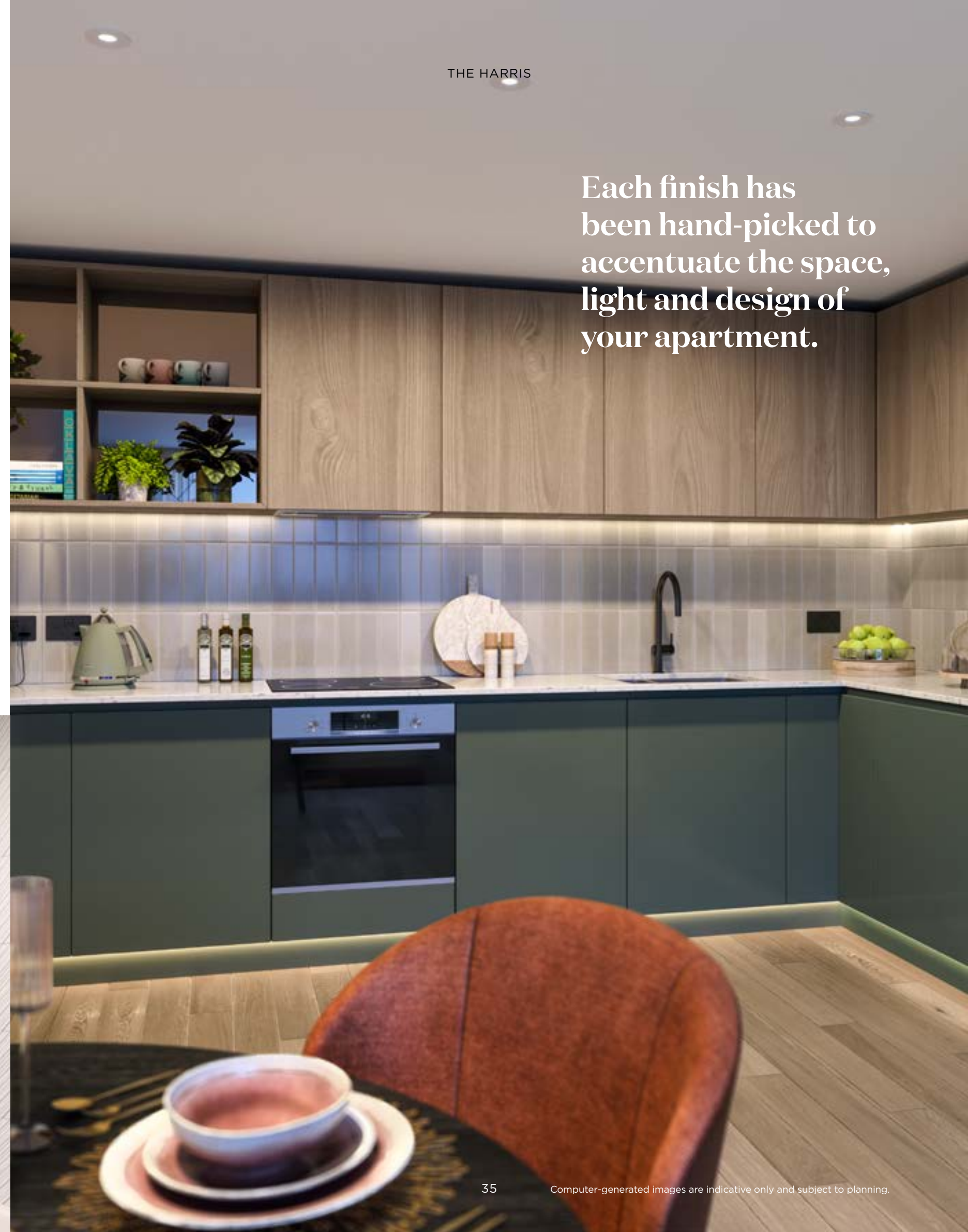

Each finish has been hand-picked to accentuate the space, light and design of your apartment.



**BATHROOM**

Stylish bathrooms with feature vanity tiles.

# STYLE ENHANCED

Berkeley has established a collection of high quality fixtures and fittings that uniquely belong to The Harris.

## KITCHENS

- Fully custom-designed fitted kitchen with handleless soft-close units
- Lacquer finish to all doors (with timber effect to high level doors)
- Silestone worktops with undermounted stainless steel sink
- Ceramic tiled splashback
- Integrated oven
- Integrated fridge/freezer
- Integrated dishwasher
- Integrated extractor hood
- Induction hob
- Space-saving pull-out recycling bins
- Washer/dryer in utility cupboard

## COMMUNAL AREAS

- Movement controlled lighting to all corridors and car park\*\*
- Lifts to all floors
- Access controlled car park and cycle storage\*\*
- Electric car charging points in undercroft car park\*\*

## BATHROOMS

- Tiling to wet area walls and floor
- Silestone countertop and tiled splashback with wash basin
- Matte black thermostatic mixer tap to wash basin
- Dual flush plate
- Matte black thermostatic mixer tap and hand-held shower over bath
- Fixed bath screen with matte black fixings
- Heated matte black towel rail
- Matte black vanity mirror, handleless with internal shelving and shaving port

## SHOWER ROOMS\*

- Tiling to wet area walls and floor
- Silestone countertop and tiled splashback with wash basin
- Dual flush plate
- Thermostatic shower mixer matte black with hand-held shower and rain shower head
- Sliding door with matte black fixings
- Heated matte black towel rail
- Matte black vanity mirror, handleless with internal shelving and shaving port

## LIGHTING/ELECTRICAL FITTINGS

- Video entry system
- USB sockets to bedroom/s
- TV point in bedroom/s
- Recessed low energy white downlights throughout

## INTERIOR FINISHES

- Timber veneer entrance door
- White internal doors
- White painted skirting
- White painted architraves
- Hallway coat/utility cupboard
- Wardrobe to bedroom one
- White painted internal walls and ceilings
- Timber effect flooring to living area, throughout kitchen and hallway
- Carpet to bedrooms

## TELECOMMUNICATIONS

- Provision for fibre broadband
- Telephone sockets to living room and bedroom one

## HEATING/VENTILATION

- Underfloor Heating throughout (except for bathroom/en-suite)
- Heated towel rail to bathrooms and ensuites
- Continuous Mechanical Extract Ventilation
- Heating control to living/dining area

## SECURITY/PEACE OF MIND

- 10-year NHBC Warranty
- Communal CCTV system
- Entrance to building via key remote fob and intercom
- Gated private courtyard and undercroft car park\*\*
- 999-year lease
- Apartment entrance door with multi-point locking system and spyhole

## PRIVATE EXTERNAL AREAS

- External private amenity space
- Paving or decking to balcony/terrace dependent on location\*
- Metal balustrades to balconies
- Wall-mounted external light to balcony/terrace



# BUILDING FOR THE FUTURE

From construction through to the finishing touches, The Green Quarter incorporates a whole host of features to help reduce environmental impact.



Rainwater is harvested for irrigating landscaped areas and the green roofs on every apartment building.



Water-saving fixtures in the bathrooms and 100% low energy lighting throughout each home.



White goods are supplied, rated B or above, as are communal heating and hot water via an Energy Centre.

\*Available to selected homes only. Computer-generated image is indicative only and subject to planning. Your attention is drawn to the fact that in rare circumstances it may not be possible to obtain the exact products or materials referred to in the specification. Berkeley reserves the right to alter, amend or update the specification, which may include changes in the colour, material or brand specified. In such cases, a similar alternative will be provided. Berkeley reserves the right to make these changes as required. A number of choices and options are available to personalise your home. Choices and options are subject to timeframes, availability and change.

\*\*Available at extra cost, subject to timeframes and availability. Parking available at extra cost to selected apartments only.

THE GREEN QUARTER



Computer-generated image is indicative only and subject to planning.

THE HARRIS

FLOORPLANS

# THE HARRIS

1 and 2 bedroom apartments



# FLOORPLATES

## LOCATION MAP

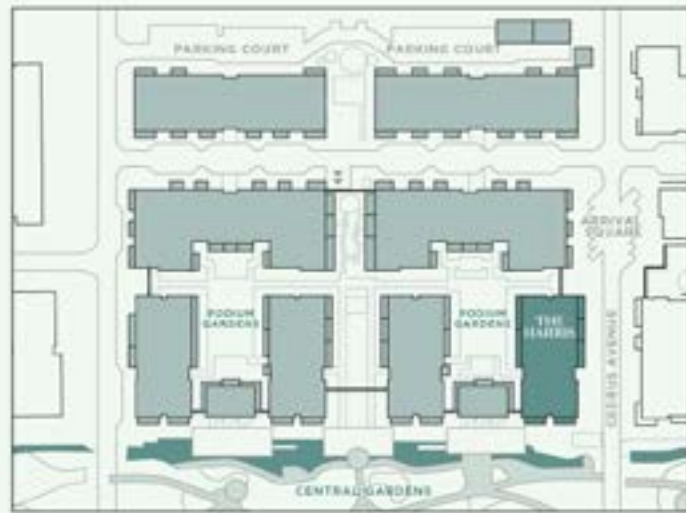

Maps are indicative only and subject to change.

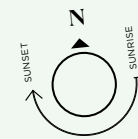

### GROUND FLOOR

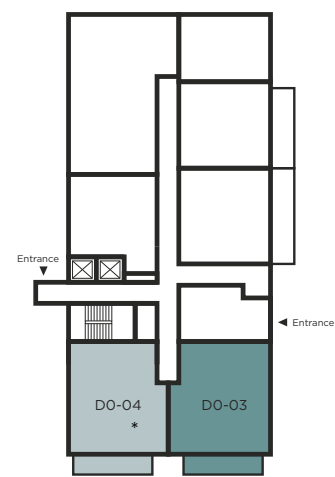

### FIRST FLOOR

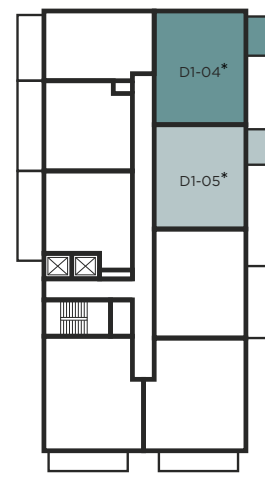

### SECOND FLOOR

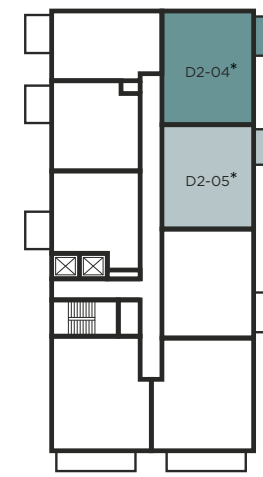

### THIRD FLOOR

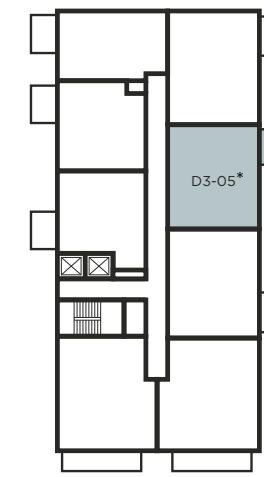

### FOURTH FLOOR

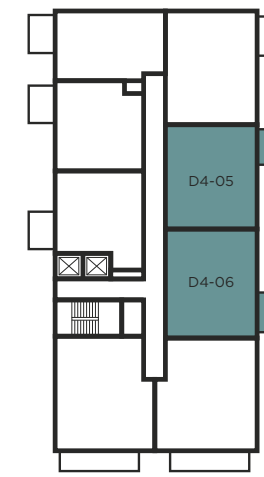

### FIFTH FLOOR

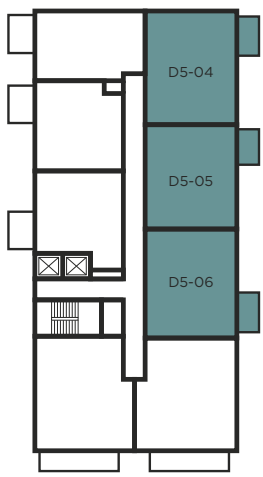

### SIXTH FLOOR

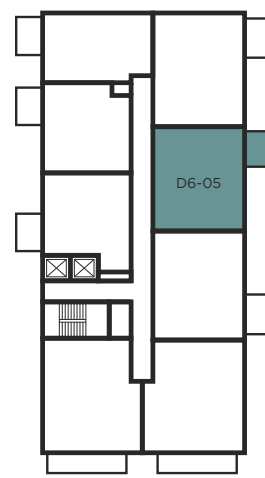

### SEVENTH FLOOR

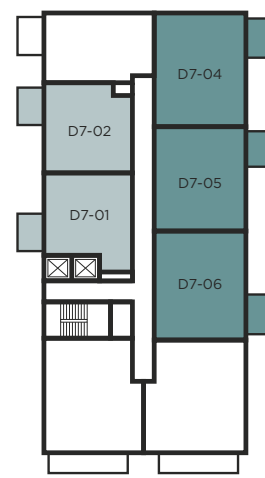

### EIGHTH FLOOR

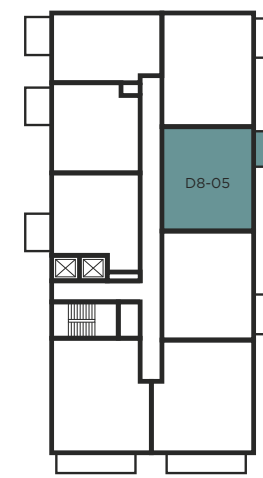

### NINTH FLOOR

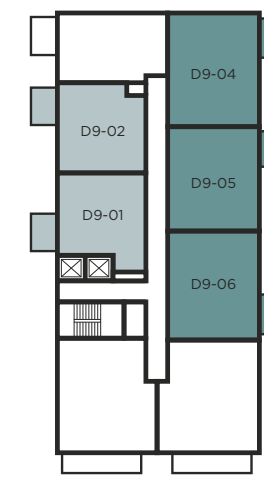

### TENTH FLOOR

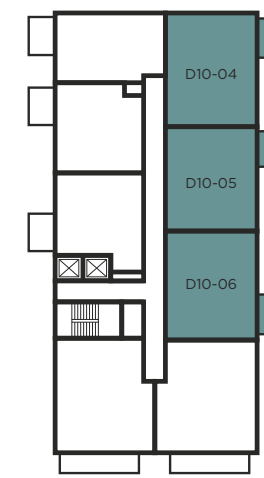

#### KEY

- 1 Bedroom Apartments
- 2 Bedroom Apartments

\*Adaptable for Wheelchair Accessibility

#### FURNITURE SIZES

##### Beds

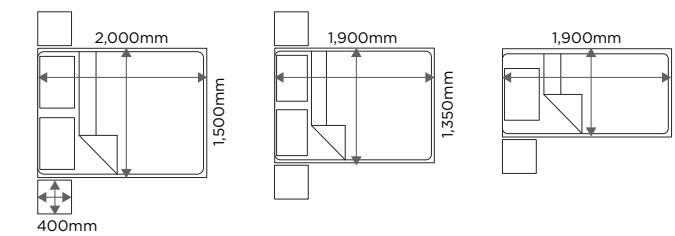

##### Seating

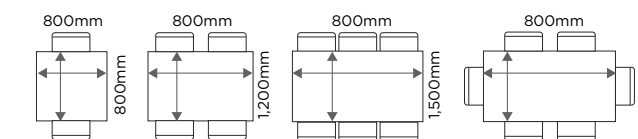
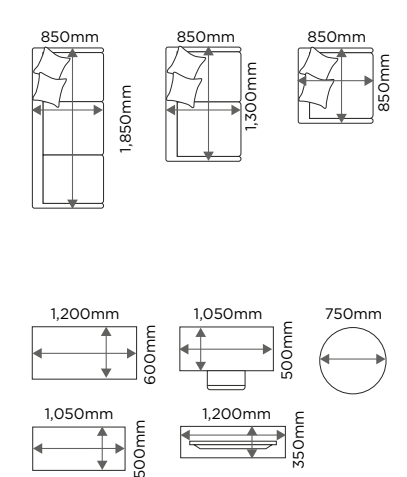

# FIND YOUR PERFECT HOME IN THE HARRIS

PLOT NO	BEDROOMS	SQ M	SQ FT	PAGE	PLOT NO	BEDROOMS	SQ M	SQ FT	PAGE
D0-03	2	71.1	765.3	53	D7-02	1	50.7	545.8	45
D0-04	1	71.1	765.4	43	D7-04	2	71.1	765.5	52
D1-04	2	68.1	733.2	47	D7-05	2	62.6	673.9	51
D1-05	1	62.6	673.9	46	D7-06	2	63.3	681.8	48
D2-04	2	68.1	733.2	47	D8-05	2	62.6	673.9	51
D2-05	1	62.6	673.9	46	D9-01	1	51.0	549.2	44
D3-05	1	62.6	673.9	46	D9-02	1	50.7	545.8	45
D4-05	2	62.6	673.9	49	D9-04	2	71.1	765.5	52
D4-06	2	63.3	681.8	48	D9-05	2	62.6	673.9	51
D5-04	2	68.1	733.2	47	D9-06	2	63.3	681.8	50
D5-05	2	62.6	673.9	49	D10-04	2	71.1	765.5	52
D5-06	2	63.3	681.8	48	D10-05	2	62.6	673.9	51
D6-05	2	62.6	673.9	51	D10-06	2	63.3	681.8	50
D7-01	1	51.0	549.2	44					

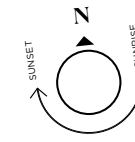

TOTAL AREA	71.10 sq m	765.4 sq ft	Kitchen	3.57m x 1.45m	11' 9" x 4' 9"
Terrace total area	10.50 sq m	113.1 sq ft	Living / Dining	4.82m x 4.49m	15' 10" x 14' 9"
			Bedroom	5.63m x 3.60m	18' 6" x 11' 10"
			Terrace	1.70m x 6.60m	5' 7" x 22' 3"

**KEY**

W Wardrobe C Cupboard U Utility ◀▶ Measurement Points WM Washing Machine  
 HIU Heat Interface Unit ▶ Apartment Entrance

Floorplans shown for The Green Quarter are for approximate measurements only. Exact layout, sizes, measurements and areas may vary within a tolerance of 5%. The net sales area is based on the RICS standard method of measurement and is the internal area of the home including internal columns and service boxing. The dimensions and areas are not intended to be used for carpet sizes, appliance sizes or items of furniture. Furniture and kitchen layouts are indicative only. Colours are indicative only and may vary depending on the customer palette selection. Views are indicative only. Landscaping on balconies and terraces is indicative only. Please note, to increase legibility these plans have been sized to fit the page. As a result this plan may not be at the same scale as those on other pages.

## 1 BEDROOM

APARTMENT: D0-04

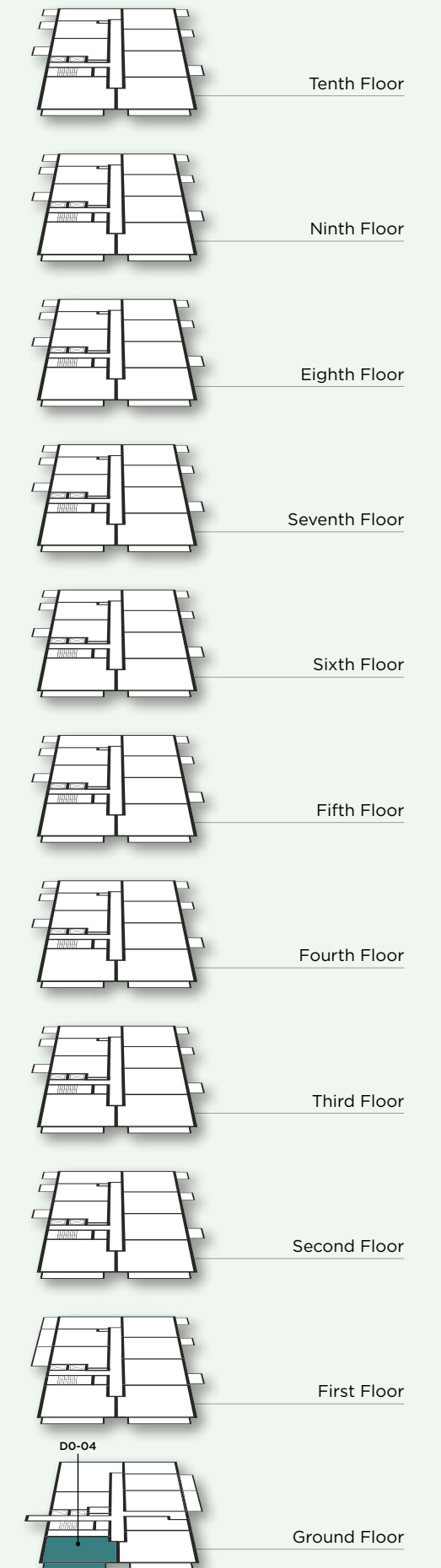

# 1 BEDROOM

APARTMENTS: D7-01 & D9-01

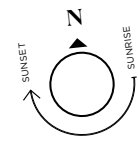
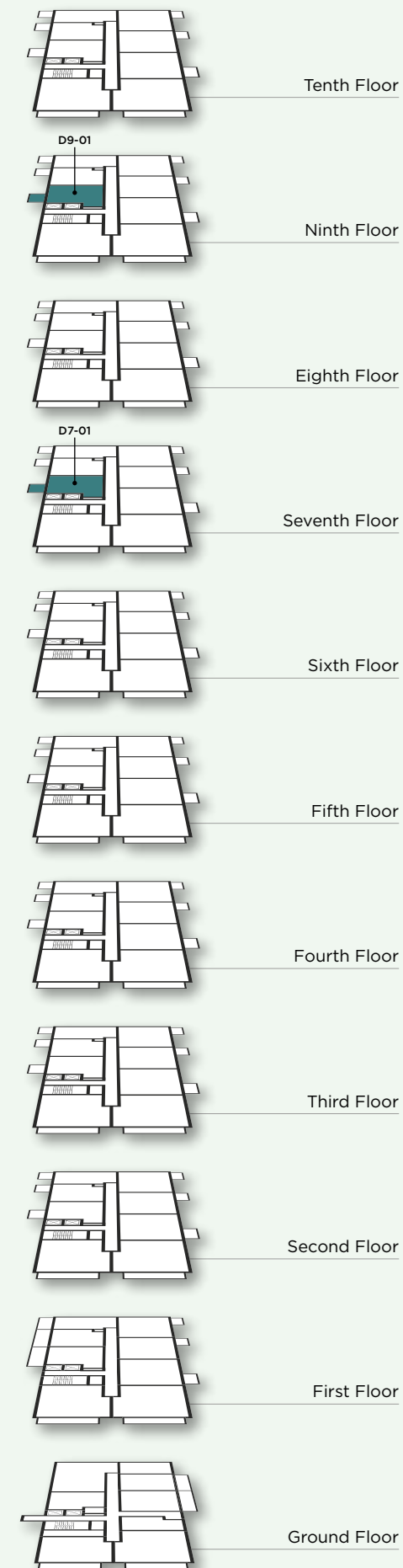

## THE GREEN QUARTER



TOTAL AREA	51.03 sq m	549.2 sq ft	Kitchen	3.21m x 2.41m	10' 6" x 7' 11"
Balcony total area	5.13 sq m	55.2 sq ft	Living / Dining	3.67m x 4.88m	12' 0" x 16' 0"
			Bedroom	2.75m x 5.10m	9' 0" x 16' 9"
			Balcony	3.02m x 1.70m	9' 11" x 5' 7"

**KEY**

W Wardrobe C Cupboard U Utility ◀▶ Measurement Points WM Washing Machine  
HIU Heat Interface Unit ▶ Apartment Entrance

Floorplans shown for The Green Quarter are for approximate measurements only. Exact layout, sizes, measurements and areas may vary within a tolerance of 5%. The net sales area is based on the RICS standard method of measurement and is the internal area of the home including internal columns and service boxing. The dimensions and areas are not intended to be used for carpet sizes, appliance sizes or items of furniture. Furniture and kitchen layouts are indicative only. Colours are indicative only and may vary depending on the customer palette selection. Views are indicative only. Landscaping on balconies and terraces is indicative only. Please note, to increase legibility these plans have been sized to fit the page. As a result this plan may not be at the same scale as those on other pages.

## THE HARRIS

# 1 BEDROOM

APARTMENTS: D7-02 & D9-02

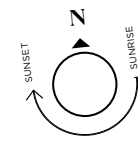
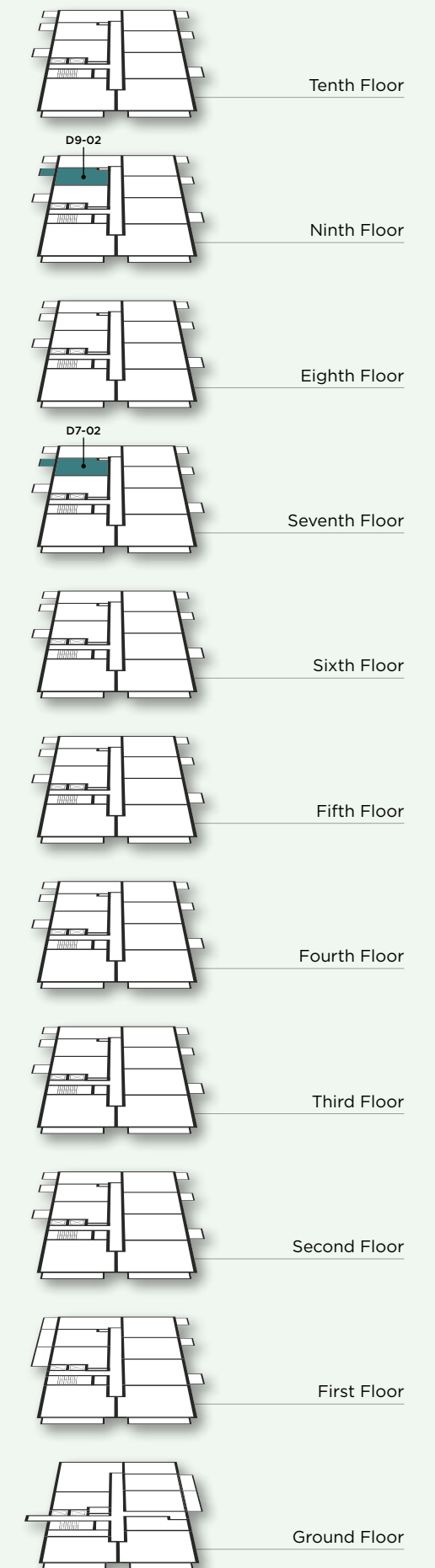

TOTAL AREA	50.71 sq m	545.8 sq ft	Kitchen	2.45m x 2.75m	8' 0" x 9' 0"
Balcony total area	5.13 sq m	55.2 sq ft	Living / Dining	4.35m x 2.83m	14' 3" x 9' 3"
			Bedroom	2.75m x 5.10m	9' 0" x 16' 9"
			Balcony	3.02m x 1.70m	9' 11" x 5' 7"

**KEY**

W Wardrobe C Cupboard U Utility ◀▶ Measurement Points WM Washing Machine  
HIU Heat Interface Unit ▶ Apartment Entrance

Floorplans shown for The Green Quarter are for approximate measurements only. Exact layout, sizes, measurements and areas may vary within a tolerance of 5%. The net sales area is based on the RICS standard method of measurement and is the internal area of the home including internal columns and service boxing. The dimensions and areas are not intended to be used for carpet sizes, appliance sizes or items of furniture. Furniture and kitchen layouts are indicative only. Colours are indicative only and may vary depending on the customer palette selection. Views are indicative only. Landscaping on balconies and terraces is indicative only. Please note, to increase legibility these plans have been sized to fit the page. As a result this plan may not be at the same scale as those on other pages.



# 1 BEDROOM

APARTMENTS: D1-05, D2-05 & D3-05

## THE GREEN QUARTER

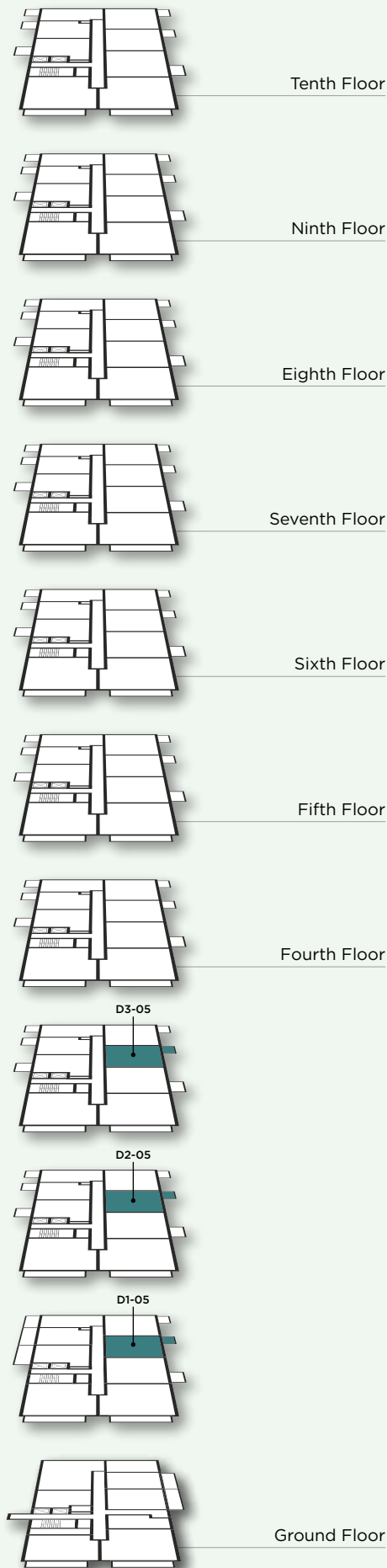
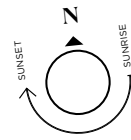

TOTAL AREA	62.61 sq m	673.9 sq ft	Kitchen	2.80m x 2.76m	9' 2" x 9' 1"
Balcony total area	5.13 sq m	55.2 sq ft	Living Room	4.81m x 4.49m	15' 10" x 14' 9"
			Bedroom	4.46m x 3.68m	14' 8" x 12' 1"
			Balcony	1.70m x 3.00m	5' 7" x 9' 11"

**KEY**

W Wardrobe C Cupboard U Utility ◀▶ Measurement Points WM Washing Machine  
HIU Heat Interface Unit ▶ Apartment Entrance

Floorplans shown for The Green Quarter are for approximate measurements only. Exact layout, sizes, measurements and areas may vary within a tolerance of 5%. The net sales area is based on the RICS standard method of measurement and is the internal area of the home including internal columns and service boxing. The dimensions and areas are not intended to be used for carpet sizes, appliance sizes or items of furniture. Furniture and kitchen layouts are indicative only. Colours are indicative only and may vary depending on the customer palette selection. Views are indicative only. Landscaping on balconies and terraces is indicative only. Please note, to increase legibility these plans have been sized to fit the page. As a result this plan may not be at the same scale as those on other pages.

## THE HARRIS

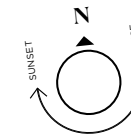

TOTAL AREA	68.12 sq m	733.2 sq ft	Kitchen	2.40m x 3.10m	7' 11" x 10' 5"
Balcony total area	6.01 sq m	65.5 sq ft	Living / Dining	5.67m x 2.38m	18' 7" x 7' 10"
			Bedroom 1	4.46m x 3.50m	14' 8" x 11' 6"
			Bedroom 2	3.56m x 2.40m	11' 8" x 7' 10"
			Balcony	1.70m x 3.50m	5' 7" x 11' 7"

**KEY**

W Wardrobe C Cupboard U Utility ◀▶ Measurement Points WM Washing Machine  
HIU Heat Interface Unit ▶ Apartment Entrance

Floorplans shown for The Green Quarter are for approximate measurements only. Exact layout, sizes, measurements and areas may vary within a tolerance of 5%. The net sales area is based on the RICS standard method of measurement and is the internal area of the home including internal columns and service boxing. The dimensions and areas are not intended to be used for carpet sizes, appliance sizes or items of furniture. Furniture and kitchen layouts are indicative only. Colours are indicative only and may vary depending on the customer palette selection. Views are indicative only. Landscaping on balconies and terraces is indicative only. Please note, to increase legibility these plans have been sized to fit the page. As a result this plan may not be at the same scale as those on other pages.

# 2 BEDROOM

APARTMENTS: D1-04, D2-04 & D5-04

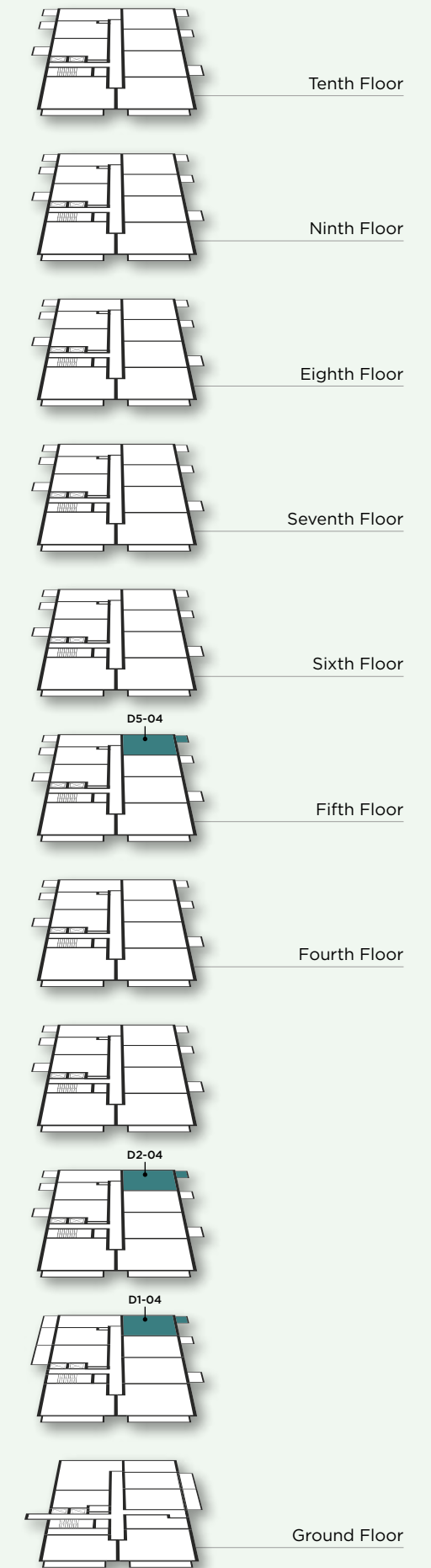

## 2 BEDROOM

APARTMENTS: D4-06, D5-06 & D7-06

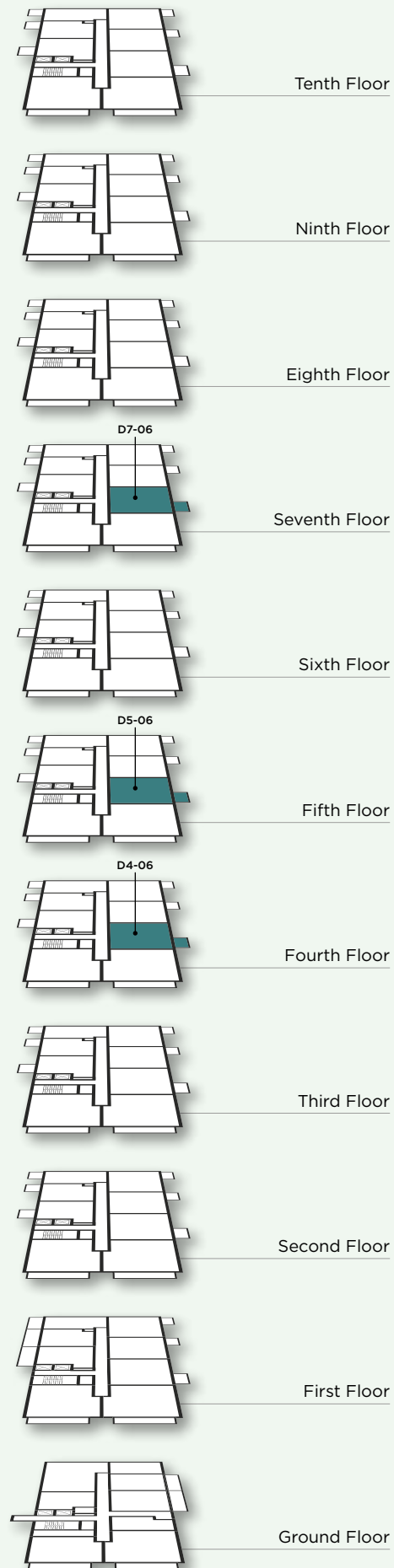
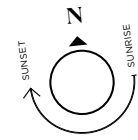

TOTAL AREA	63.34 sq m	681.8 sq ft	Kitchen	3.68m x 2.60m	12' 1" x 8' 6"
Balcony total area	6.09 sq m	65.6 sq ft	Living / Dining	3.25m x 4.70m	10' 8" x 15' 5"
			Bedroom 1	2.75m x 5.10m	9' 0" x 16' 9"
			Bedroom 2	2.50m x 3.55m	8' 2" x 11' 8"
			Balcony	3.58m x 1.70m	11' 9" x 5' 7"

### KEY

W Wardrobe C Cupboard U Utility ◀▶ Measurement Points WM Washing Machine  
HIU Heat Interface Unit ▶ Apartment Entrance

Floorplans shown for The Green Quarter are for approximate measurements only. Exact layout, sizes, measurements and areas may vary within a tolerance of 5%. The net sales area is based on the RICS standard method of measurement and is the internal area of the home including internal columns and service boxing. The dimensions and areas are not intended to be used for carpet sizes, appliance sizes or items of furniture. Furniture and kitchen layouts are indicative only. Colours are indicative only and may vary depending on the customer palette selection. Views are indicative only. Landscaping on balconies and terraces is indicative only. Please note, to increase legibility these plans have been sized to fit the page. As a result this plan may not be at the same scale as those on other pages.

## THE HARRIS

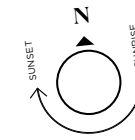

## 2 BEDROOM

APARTMENTS: D4-05 & D5-05

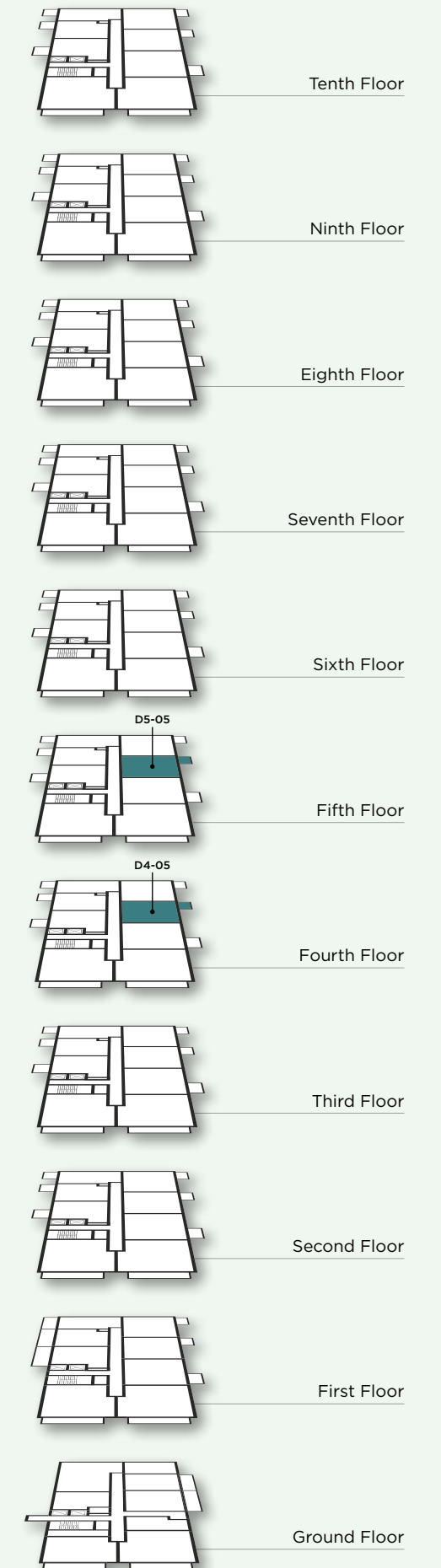

TOTAL AREA	62.61 sq m	673.9 sq ft	Kitchen	3.34m x 2.60m	11' 0" x 8' 6"
Balcony total area	6.01 sq m	64.6 sq ft	Living / Dining	3.15m x 4.70m	10' 4" x 15' 5"
			Bedroom 1	2.75m x 5.10m	9' 0" x 16' 9"
			Bedroom 2	2.50m x 3.55m	8' 2" x 11' 8"
			Balcony	3.53m x 1.70m	11' 7" x 5' 7"

### KEY

W Wardrobe C Cupboard U Utility ◀▶ Measurement Points WM Washing Machine  
HIU Heat Interface Unit ▶ Apartment Entrance

Floorplans shown for The Green Quarter are for approximate measurements only. Exact layout, sizes, measurements and areas may vary within a tolerance of 5%. The net sales area is based on the RICS standard method of measurement and is the internal area of the home including internal columns and service boxing. The dimensions and areas are not intended to be used for carpet sizes, appliance sizes or items of furniture. Furniture and kitchen layouts are indicative only. Colours are indicative only and may vary depending on the customer palette selection. Views are indicative only. Landscaping on balconies and terraces is indicative only. Please note, to increase legibility these plans have been sized to fit the page. As a result this plan may not be at the same scale as those on other pages.

## 2 BEDROOM

APARTMENTS: D9-06 & D10-06

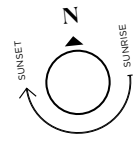
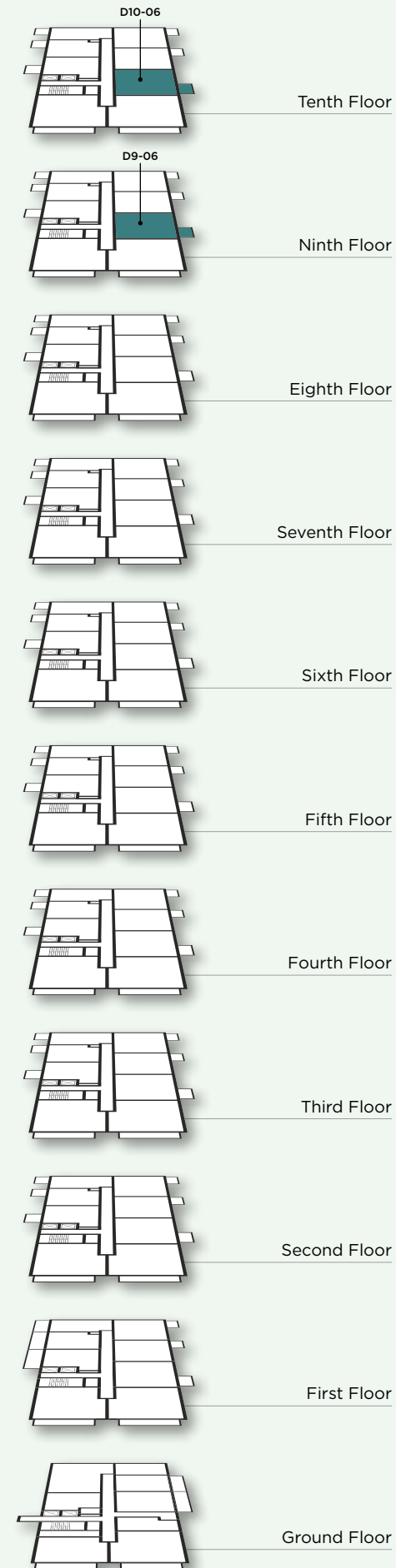

### THE GREEN QUARTER



TOTAL AREA	63.64 sq m	681.8 sq ft	Kitchen	2.45m x 2.23m	8' 0" x 7' 4"
Balcony total area	6.01 sq m	64.6 sq ft	Living / Dining	4.85m x 3.25m	15' 11" x 10' 8"
			Bedroom 1	4.97m x 2.82m	16' 4" x 9' 3"
			Bedroom 2	3.65m x 2.43m	12' 0" x 8' 0"
			Balcony	3.53m x 1.70m	11' 7" x 5' 7"

**KEY**

W Wardrobe C Cupboard U Utility ◀▶ Measurement Points WM Washing Machine  
HIU Heat Interface Unit ▶ Apartment Entrance

Floorplans shown for The Green Quarter are for approximate measurements only. Exact layout, sizes, measurements and areas may vary within a tolerance of 5%. The net sales area is based on the RICS standard method of measurement and is the internal area of the home including internal columns and service boxing. The dimensions and areas are not intended to be used for carpet sizes, appliance sizes or items of furniture. Furniture and kitchen layouts are indicative only. Colours are indicative only and may vary depending on the customer palette selection. Views are indicative only. Landscaping on balconies and terraces is indicative only. Please note, to increase legibility these plans have been sized to fit the page. As a result this plan may not be at the same scale as those on other pages.

### THE HARRIS

## 2 BEDROOM

APARTMENTS: D6-05, D7-05, D8-05, D9-05 & D10-05

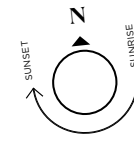
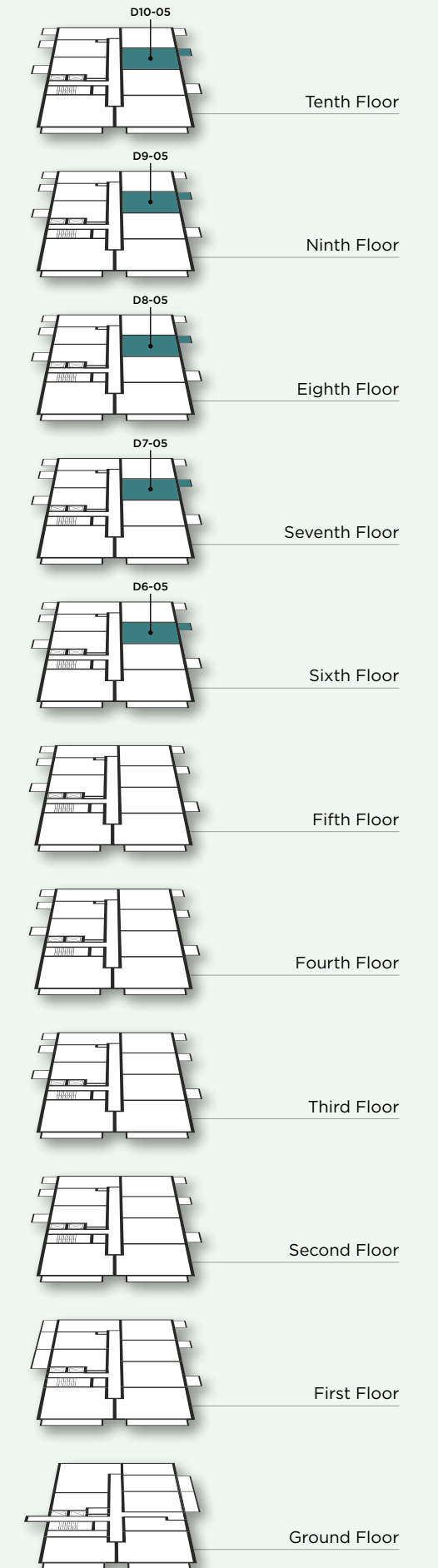

TOTAL AREA	62.61 sq m	673.9 sq ft	Kitchen	2.45m x 2.13m	8' 0" x 7' 0"
Balcony total area	6.01 sq m	64.6 sq ft	Living / Dining	4.85m x 3.15m	15' 11" x 10' 4"
			Bedroom 1	4.97m x 2.82m	16' 4" x 9' 3"
			Bedroom 2	3.65m x 2.43m	12' 0" x 8' 0"
			Balcony	3.53m x 1.70m	11' 7" x 5' 7"

**KEY**

W Wardrobe C Cupboard U Utility ◀▶ Measurement Points WM Washing Machine  
HIU Heat Interface Unit ▶ Apartment Entrance

Floorplans shown for The Green Quarter are for approximate measurements only. Exact layout, sizes, measurements and areas may vary within a tolerance of 5%. The net sales area is based on the RICS standard method of measurement and is the internal area of the home including internal columns and service boxing. The dimensions and areas are not intended to be used for carpet sizes, appliance sizes or items of furniture. Furniture and kitchen layouts are indicative only. Colours are indicative only and may vary depending on the customer palette selection. Views are indicative only. Landscaping on balconies and terraces is indicative only. Please note, to increase legibility these plans have been sized to fit the page. As a result this plan may not be at the same scale as those on other pages.

## 2 BEDROOM

APARTMENTS: D7-04, D9-04 & D10-04

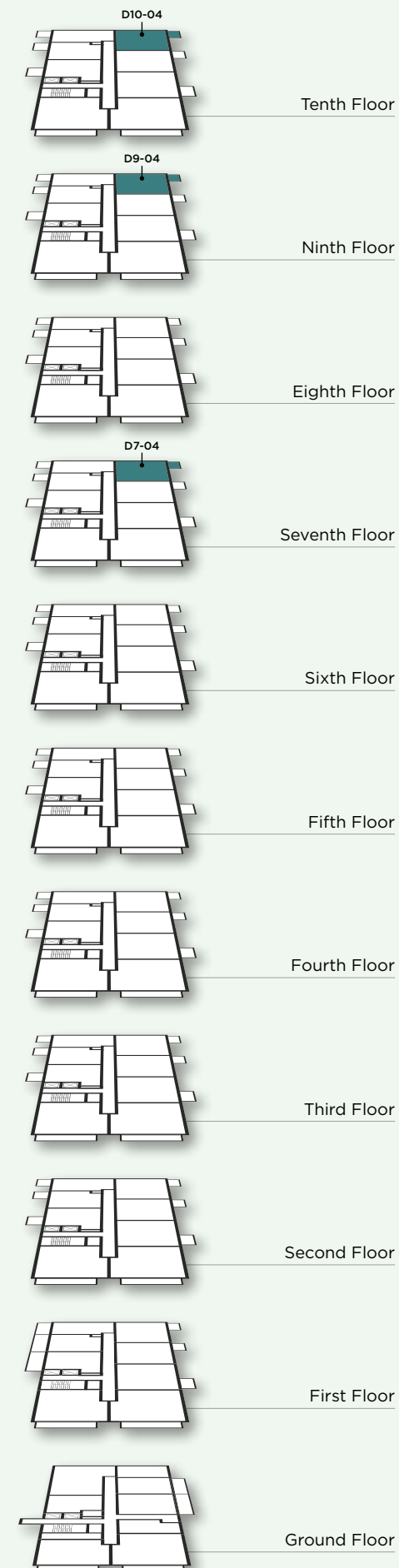
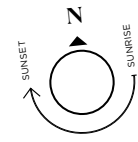

TOTAL AREA	71.12 sq m	765.5 sq ft	Kitchen	2.94m x 2.45m	9' 8" x 8' 0"
Balcony total area	7.81 sq m	84.1 sq ft	Living / Dining	3.39m x 5.45m	11' 2" x 17' 10"
			Bedroom 1	3.07m x 4.97m	10' 1" x 16' 4"
			Bedroom 2	2.75m x 4.40m	9' 0" x 14' 5"
			Balcony	4.60m x 1.70m	15' 1" x 5' 7"

### KEY

W Wardrobe C Cupboard U Utility ◀▶ Measurement Points WM Washing Machine  
HIU Heat Interface Unit ▶ Apartment Entrance

Floorplans shown for The Green Quarter are for approximate measurements only. Exact layout, sizes, measurements and areas may vary within a tolerance of 5%. The net sales area is based on the RICS standard method of measurement and is the internal area of the home including internal columns and service boxing. The dimensions and areas are not intended to be used for carpet sizes, appliance sizes or items of furniture. Furniture and kitchen layouts are indicative only. Colours are indicative only and may vary depending on the customer palette selection. Views are indicative only. Landscaping on balconies and terraces is indicative only. Please note, to increase legibility these plans have been sized to fit the page. As a result this plan may not be at the same scale as those on other pages.

## THE HARRIS

## 2 BEDROOM

APARTMENT: D0-03

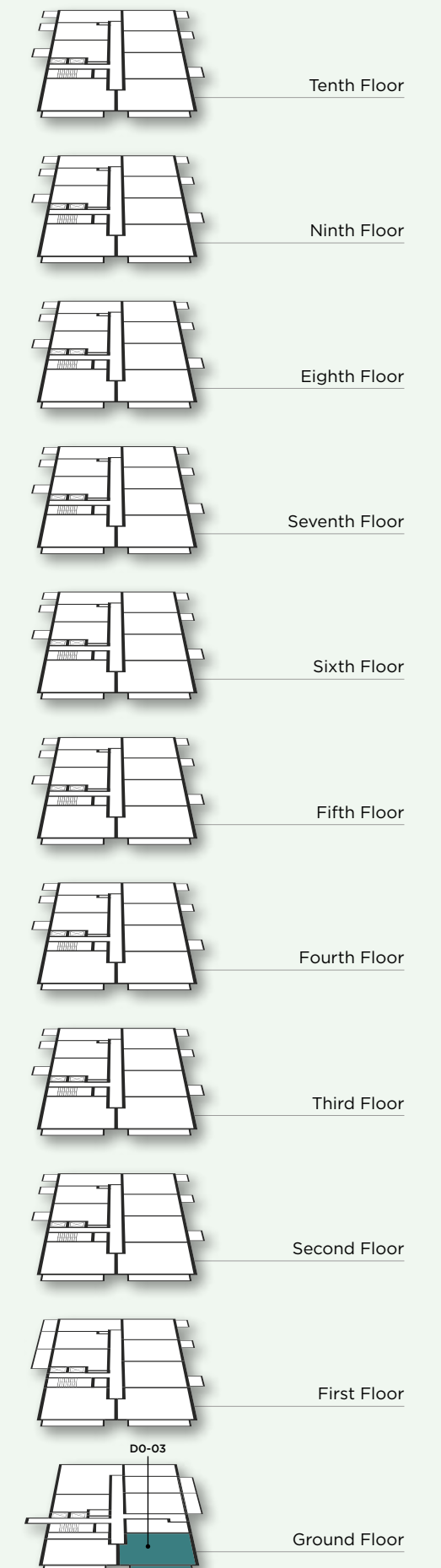
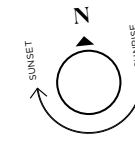

TOTAL AREA	71.10 sq m	765.3 sq ft	Kitchen	1.60m x 3.70m	5' 3" x 12' 2"
Terrace total area	10.80 sq m	116.5 sq ft	Living / Dining	4.33m x 4.30m	14' 3" x 14' 1"
			Bedroom 1	3.07m x 4.97m	10' 1" x 16' 4"
			Bedroom 2	2.83m x 3.80m	9' 4" x 12' 6"
			Terrace	1.60m x 6.60m	5' 5" x 21' 9"

### KEY

W Wardrobe C Cupboard U Utility ◀▶ Measurement Points WM Washing Machine  
HIU Heat Interface Unit ▶ Apartment Entrance

Floorplans shown for The Green Quarter are for approximate measurements only. Exact layout, sizes, measurements and areas may vary within a tolerance of 5%. The net sales area is based on the RICS standard method of measurement and is the internal area of the home including internal columns and service boxing. The dimensions and areas are not intended to be used for carpet sizes, appliance sizes or items of furniture. Furniture and kitchen layouts are indicative only. Colours are indicative only and may vary depending on the customer palette selection. Views are indicative only. Landscaping on balconies and terraces is indicative only. Please note, to increase legibility these plans have been sized to fit the page. As a result this plan may not be at the same scale as those on other pages.

# DESIGNED FOR LIFE

At Berkeley, we are committed to creating great places where people love to live, work and relax. Where the homes are light-filled, adaptable and finished to very high standards. Where carefully planned public areas enhance wellbeing and quality of life for residents and visitors. Where people feel a sense of community.

## CUSTOMERS DRIVE ALL OUR DECISIONS

We achieve that by putting our customers at the heart of everything we do. First, we strive to understand what our customers want and need – well-built homes, in a pleasant and safe neighbourhood, with plenty of amenities and good transport connections. Then we apply that understanding to all our planning and design decisions.

And for every new development, we challenge ourselves to go further, to improve and innovate, ensuring we satisfy the real needs of our customers in inspiring and sustainable ways.

## CHOICE AND DIVERSITY

No two Berkeley customers are the same, so we aim to offer a wide choice of property location, size and type. From central London to major towns and cities; from market towns to rural villages, countryside to the coast – we build in locations our customers love. And whatever home you are looking for, whether that's a city penthouse, a modern studio apartment or traditional family home, you will find the perfect fit for your lifestyle.

## QUALITY FIRST TO LAST

Quality is the defining characteristic of Berkeley developments, right down to the very last detail. We choose our locations, style of homes, construction practices, materials and specifications with great care. When you buy a new home from Berkeley you can be safe in the knowledge that it is built to high standards of design and quality, has low environmental impact and that you will receive a professional, efficient and helpful service from us. For extra peace of mind, all new properties come with a 10-year build warranty.

## GREEN LIVING

For Berkeley, sustainability isn't simply the latest buzzword. We are committed to creating a better environment within our developments and in the areas that surround them. That's why we build on brownfield sites whenever we can, bringing new life to disused and unloved spaces. We take care to protect the natural environment and enhance biodiversity. All our homes are designed to reduce water and energy consumption, and to enable residents to recycle waste.

## COMMITMENT TO THE FUTURE

When we plan a development, we take a long-term view of how the community we create can thrive in years to come. Our aim is to permanently enhance the neighbourhoods in which they are located, through intelligent design, quality landscaping, sympathetic architecture or restoration, and high standards of sustainability. We don't just build for today; we build for the future too.



# TRANSFORMING TOMORROW

At Berkeley Group our passion and purpose is to build quality homes, strengthen communities and improve people's lives. We are innovating, pushing boundaries and taking action to ensure we have a long-term, positive impact that is good for our customers, the communities we touch, our business and the world around us. We transform underused sites into exceptional places and we're also transforming the way we work; embracing technology and raising standards, as we continue to deliver an outstanding customer experience and create high-quality homes that delight our customers. Our Vision 2030 is our ten year plan which sets out how we will achieve this.



## TRANSFORMING PLACES

Working with local people and partners we create welcoming and connected neighbourhoods where you can be proud to live.



## TRANSFORMING LIFESTYLES

Taking action on climate change and giving you ways to live more sustainably. We're building efficient homes that use less energy over their lifetime, with sustainable travel choices on the doorstep.



## TRANSFORMING NATURE

Creating beautiful places with habitats that help nature to thrive, meaning that every site is left with more nature than when we began.



## TRANSFORMING FUTURES

Helping people to reach their potential through apprenticeships and training, and programmes supported by the Berkeley Foundation.

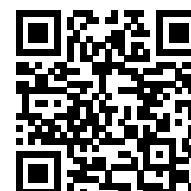

Please scan this QR code for more information on how we are TRANSFORMING TOMORROW



# THIS IS HOW WE ARE ENSURING SUSTAINABILITY AT THE GREEN QUARTER

## PEOPLE, PLANET, PROSPERITY

Sustainability is fundamental to Berkeley's ethos. In simple terms, we want to ensure the long-term health, wellbeing and prosperity of people and the planet. There are a range of ways we are managing and minimising the environmental impact of our operations and delivery of homes and communities. These are the initiatives we have implemented at The Green Quarter.

## NATURE AND BIODIVERSITY

Parkland, trees, flowers, green roofs, ponds, hedges, gardens - these are the fundamentals of a thriving natural environment that can be enjoyed by everyone. They are all part of our commitment to net biodiversity gain on our developments. Within and around The Green Quarter, we have created natural habitats that encourage wildlife to flourish. We are working with the London Wildlife Trust and ALD (Applied Landscaping Design) to engage residents in the natural landscapes that we have created.

## WASTE AND RECYCLING

We actively encourage all residents to reduce their waste wherever possible. In addition to external recycling bins, we provide integrated recycling bins in kitchens to make it easier to separate and recycle waste.

## WATER EFFICIENCY

Our homes are designed to high water efficiency standards and are fitted with dual flush WCs, and low-flow taps and showerheads which use less water without compromising convenience and comfort. We also suggest simple steps to reduce water consumption, such as not leaving taps running unnecessarily.

## ENERGY EFFICIENCY

Efficient use of electricity and gas helps lower fuel bills and reduces carbon emissions. Our homes have been designed to use less energy than a standard home. They have enhanced levels of thermal insulation, air-tightness and Continuous Mechanical Extract Ventilation. All lighting is low energy and kitchen appliances are B rated or above.

## NOISE REDUCTION

We can't eliminate noise, but we consider the impact of noise in the design of our homes. We consider external noise, such as from nearby roads, and internal noise including the transfer between rooms and floors. We incorporate measures to reduce the different types of noise wherever possible to create a quieter environment.

## CLEAN AIR

It is hard to avoid polluted air, particularly in our cities. Throughout The Green Quarter we have planted trees, shrubs and flower beds to help create a cleaner air environment. Within our homes we provide mechanical ventilation to filter the internal air.

## SUSTAINABLE TRANSPORT

The Green Quarter is within walking distance of the railway station. Electric car charging points, car club and fitness trails encourage the use of sustainable methods of transport, to help reduce air pollution around the development and the wider area. These active methods of transport also help encourage healthier lifestyles.

## STEWARDSHIP

Maintaining our communal open spaces and facilities in perpetuity is an important benefit to the whole community. We work with FirstPort and residents to ensure the development remains in pristine condition.

## FUTURE-PROOF DESIGN

From the early stages of design, we assess how our homes will stand up to the future effects of climate change, such as how they might be impacted by higher summer temperatures, periods of drought, or more extreme rainfall. We are constantly researching how we can ensure our homes and developments are more resilient to these extremes to understand what new innovative technologies we should use in our future designs.

## AWARD WINNING

Berkeley Group was awarded 'Sustainable Housebuilder of the Year' in 2020 for the second year running and at The Green Quarter, it's no different.

The Green Apple Silver Award 2022 was won by The Green Quarter by promoting environmental best practice throughout the development.

Berkeley Group was also awarded the Carbon Reduction Award at the 2022 National Sustainability Award by using HVO biofuel on our sites that resulted in significant carbon reduction.



# MYHOME PLUS

MyHome Plus is an online service that is designed to help you manage key aspects of your new home at any time from anywhere around the world.

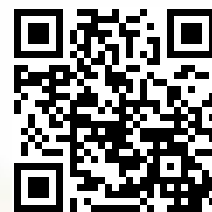

PLEASE SCAN TO SEE MORE ABOUT MYHOME PLUS

This section provides you with an overview of MyHome Plus' Key features to enhance your customer journey.

## 01

### FILING CABINET

In the filing cabinet section you can access documentation relating to your new home immediately at your own convenience.



## 02

### MEET THE TEAM

This section provides an introduction to your dedicated Sales Consultant, Customer Relations Manager and Customer Service Manager. You will be able to view their contact details and to contact them directly from the platform.

## 03

### OPTIONS & CHOICES

When you buy a home with us, you will have the option to choose some of your home finishes. This will be subject to the development and property building stage but it's a chance to make it feel truly yours. You will be able to see the different options, the selection deadline date and submit your choice in this section of MyHome Plus. See the "next steps" section for further detail on this.

## 04

### CONSTRUCTION PROGRESS

Under this section, regular updates on the construction of your new property will be provided, keeping you up to date on the progress on site and the local area. Your Customer Relations Manager will issue regular newsletters and photographs to this section throughout your journey.

## 05

### MY GUIDES

View and download your buying and living guides to support you step-by-step through your journey with us.

## NEXT STEPS

### 01

Your Sales Consultant will send you instructions to create and validate your MyHome account. Once your account is validated, your Sales Consultant will assign your property to your MyHome account and your account will be upgraded to a MyHome Plus account.

### 02

Your Customer Relations Manager will then be in touch to invite you in to our Show Apartment to view the interior selections available for the internal finishes that you have an option to select.\*

\*If you cannot make it to the appointment, the options can be discussed over the telephone and selected via MyHome Plus. Customer Service will need to receive your choices selection by the deadline date, which will be given in advance.



Photograph of Central Gardens at The Green Quarter

# OUR RECENT ACCOLADES

The Berkeley Group, and all the companies within the Group, has continued to strive for the best, and has received many awards for design, construction and health & safety.

It is not only experts from our industry we have received recognition from, 98% of our customers would recommend us to a friend.



**Britain's Most Admired Companies 2020**  
Sixth most admired company in Britain and placed first within the Home Construction category



**National Sustainability Awards 2022**  
Carbon Reduction Award



**What House? Housebuilder of the Year 2022**



**In-house Research Awards 2022**  
Outstanding Award 2022 and 2022 Gold Award for Customer Satisfaction



**Better Society Awards 2022**  
Transformation Award



**Investor in Customers®**  
Gold 2018

**Investor in Customers®**  
Gold 2020

**Investor in Customers®**  
Gold 2022

**Investor in Customers**  
Gold 2018, 2020 and 2022



**Job Crowd Top Company 2022**  
For Graduates To Work For



**Building Awards 2022**  
Housebuilder of the Year



**RESI Awards 2022**  
Large Developer of the Year





# CONTACT US

**MARKETING SUITE ADDRESS:**

1 Randolph Road, Southall UB1 1BL

Opening Times

**Monday to Saturday 10am - 6pm**

**Sunday 10am - 5pm**

**Bank Holidays 10am - 4pm**

For more information please visit our website or contact our Sales Team:

[www.the-green-quarter.com](http://www.the-green-quarter.com)

[tgqsales@berkeleygroup.co.uk](mailto:tgqsales@berkeleygroup.co.uk)

T: 020 3930 5295

Follow us @tgqwestlondon 

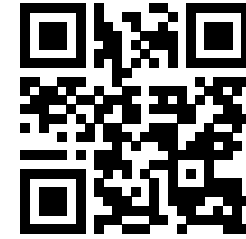

Please scan to see the location on Google maps



Map not to scale



The information in this document is indicative and is intended to act as a guide only as to the finished product. Accordingly, due to Berkeley policy of continuous improvement, the finished product may vary from the information provided. These particulars should not be relied upon as statements of fact or representations and applicants must satisfy themselves by inspection or otherwise as to their correctness. This information does not constitute a contract or warranty. The dimensions given on plans are subject to minor variations and are not intended to be used for carpet sizes, appliance sizes or items of furniture. The Green Quarter is a marketing name and will not necessarily form part of the approved postal address. Applicants are advised to contact Berkeley to ascertain the availability of any particular property. The Green Quarter was granted planning permission by Hillingdon Council (planning reference: 54814/APP/2017/604 dated 19 September 2017) and Ealing Council (planning reference: 171562VAR dated 16 October 2017). Through the purchase of a property at The Green Quarter, the buyer is acquiring an apartment with a 999-year leasehold. You should review all relevant information and documents carefully before making a purchase decision. If in doubt, please seek independent professional advice before making a purchase decision. Date of issue: March 2023. A724/05CA/0923.



THE-GREEN-QUARTER.COM



**Berkeley**  
Designed for life